

Part Number: PTS30-42060

Kit Contents

Item #	Quantity Reqd.	Description
1	1	Tube Step – Driver Side
2	1	Tube Step – Passenger Side
3	1	Bracket Rail – Driver Side
4	1	Bracket Rail – Passenger Side
5	1	Hardware Bag

Hardware Bag Contents

Item #	Quantity Reqd.	Description
1	4	Bolt Arm Assembly
2	4	1/2" Nylock Nut
3	4	1/2" Flat Washer
4	4	Plastic Bolt Retainer - Black
5	4	Pinch Weld Clamp Plate
6	8	M8 Carriage Bolt
7	8	M8 Flat Washer
8	8	M8 Nylock Nut
9	16	M6 Bolt (tube to brkt)
10	16	M6 Washer (tube to brkt)
11	16	M6 Lock Washer (tube to brkt)
12	1	Jack Label - Jack
13	1	Jack Label - Page
14	1	Jack Label - Back Cover

Additional Items Required For Installation

Item #	Quantity Reqd.	Description

Conflicts

None

Recommended Tools

Personal & Vehicle Protection	Notes
Personal Safety	Gloves, Eye Protection
Special Tools	Notes
Installation Tools	Notes
Ratchet	
Deep Socket	19mm (3/4")
Socket	10mm
Ratcheting Boxend Wrench	13mm
Torque Wrench	lbs-ft
Torque Adapter	13mm Snap-on FRDHM13
Special Chemicals	Notes
None	

General Applicability

Note-

Recommended Sequence of Application

Item #	Accessory
1	
2	
3	

*Mandatory

Vehicle Service Parts (may be required for reassembly)

Item #	Quantity Reqd.	Description
1		
2		
3		

Legend

 **STOP:** Damage to the vehicle may occur. Do not proceed until process has been complied with.

 **OPERATOR SAFETY:** Use caution to avoid risk of injury.

 **CAUTION:** A process that must be carefully observed in order to reduce the risk of damage to the accessory/vehicle and to ensure a quality installation.

 **TOOLS & EQUIPMENT:** Used in Figures calls out the specific tools and equipment recommended for this process.

 **REVISION MARK:** This mark highlights a change in installation with respect to previous issues.

The steps as required to calculate torque when using a torque adapter are as follows:

1. Determine the amount of torque required to properly set the fastener. (17 lbs-ft)
2. Determine the length of the torque wrench from the center of the grip to the center of the square drive (remember that this changes as you adjust the torque wrench setting).
3. Multiply the amount of torque you are trying to apply (1) by the length of the torque wrench from (2) above.
4. Add 2" for the torque adapter length to (2).

Divide the result from (3) by the result from (4). The result is the torque wrench setting required to properly torque the fastener.

Care must be taken when installing this accessory to ensure damage does not occur to the vehicle. The installation of this accessory should follow approved guidelines to ensure a quality installation.

These guidelines can be found in the "Accessory Installation Practices" document.

This document covers such items as:-

- Vehicle Protection (use of covers and blankets, cleaning chemicals, etc.).
- Safety (eye protection, rechecking torque procedure, etc.).
- Vehicle Disassembly/Reassembly (panel removal, part storage, etc.).
- Electrical Component Disassembly/Reassembly (battery disconnection, connector removal, etc.).

Please see your Toyota dealer for a copy of this document.

1. Installation Preparation

- (a) Inspect and verify the kit contents.
- (b) Ensure the mounting area is clean and free of dirt and debris.
- (c) Prepare the hardware.
 - (1) Slide the plastic bolt retainers onto the threads of the bolt arm and leave a 1/4" gap. (Fig. 1-1)
- (d) Attach the tube step to the bracket rail at each mounting location using (4) M6 bolts, lock washers and washers. (Fig 1-2)
 - (1) Note orientation of tube and bracket. The tubes and brackets are marked "LEFT" and "RIGHT". Mate the "LEFT" tube to the "LEFT" bracket and the "RIGHT" tube to the "RIGHT" bracket (Fig. 1-3)
 - (2) The ends of the tubes should curve in toward the bracket. (Fig. 1-3)
 - (3) Position the tubes as far out from the bracket as possible.
 - (4) Torque the step tube to bracket rail bolts to 84 lbs-in.

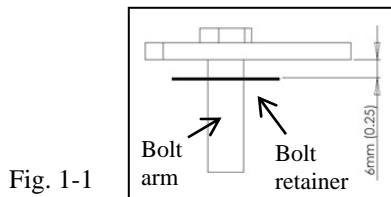

Fig. 1-1

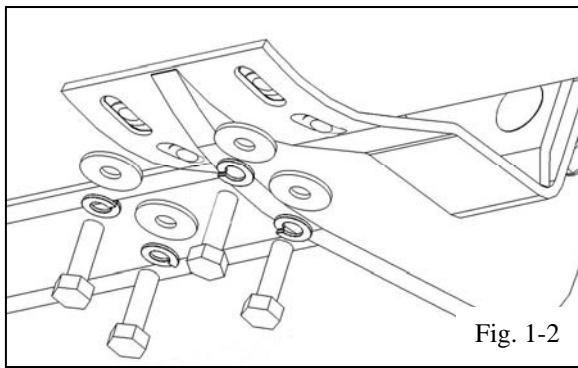

Fig. 1-2

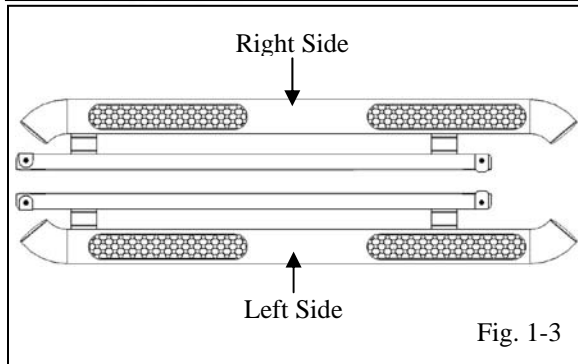
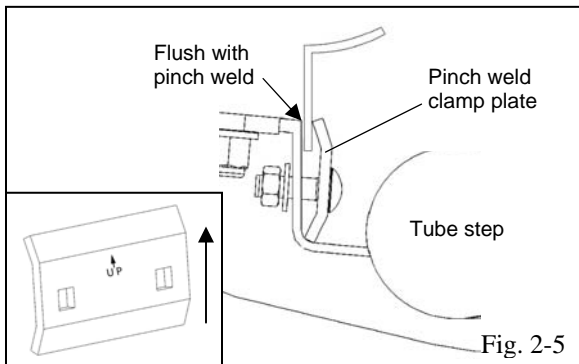
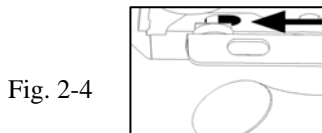
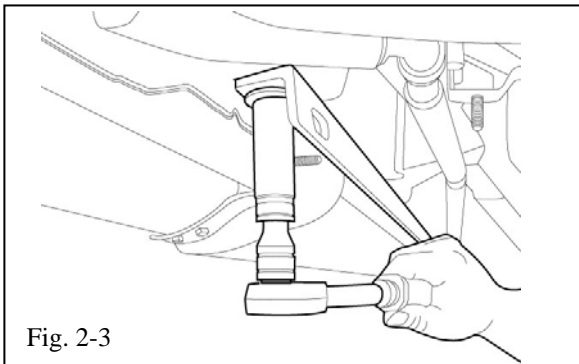
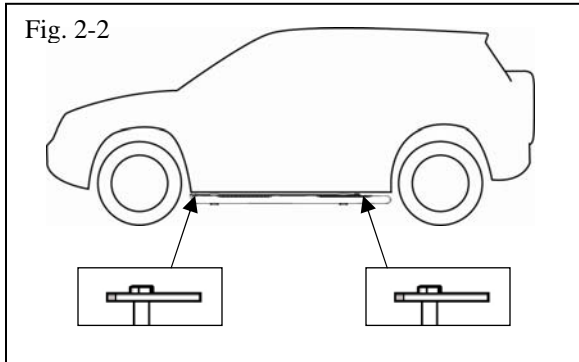
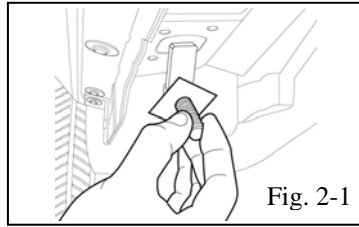

Fig. 1-3



2. Installation

- (a) Locate the two oval holes in the underside of the rocker and insert a bolt arm assembly into each of the oval holes. (Fig. 2-1)

- (1) The longer end of the bolt arm assembly should be positioned **rearward** for both locations. (Fig. 2-2)

- (b) Once installed, slide the plastic bolt retainer snug against the rocker panel.

- (c) Install Tube Step/ Bracket Rail assembly.

NOTE: The assistance of another person is highly recommended.

- (1) Align the (2) bracket rail holes (D shaped spacer toward front) over the previously installed bolts and install with washer and nut. (Fig 2-3)

- (2) Slide the tube assembly to forward most position until bolts contact front edge of oval hole. (Fig. 2-4)

- (3) Flush the bracket assembly against the pinch weld flange, and tighten nut until snug. Do not tighten completely.

- (d) Install the pinch weld clamp plate using the M8 carriage bolts, flat washers and nyloc nuts as shown. (Fig. 2-5)

- (1) Position the pinch clamp plate based on the orientation marking. (Fig. 2-5 inset)

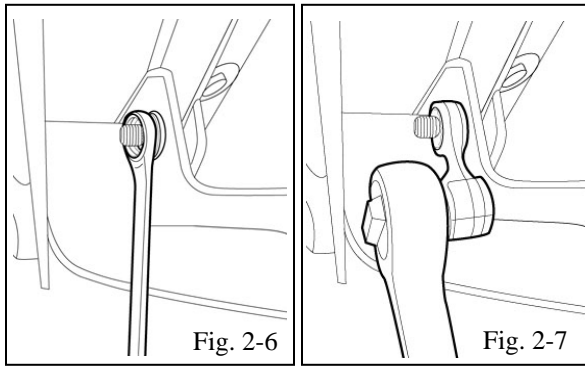

- (e) Using a ratcheting box end wrench, tighten until snug. (Fig 2-6)
- (f) Using the torque wrench adapter, torque to 17 lbs-ft. (Fig. 2-7)
 - (1) **IMPORTANT!** 17 lbs-ft is the torque for the bolts. When using the torque adapter, use the conversion method on the page 1 of the instructions to determine the torque wrench setting.
- (g) Fully tighten the bracket rail to the rocker.
 - (1) Torque to 75 lbs-ft (65 lbs-ft. min/85 lbs-ft. max). (Fig. 2-3)
- (h) Repeat all steps above on opposite side of vehicle.

Table of contents		Page
1	OPERATION OF INSTRUMENTS AND CONTROLS	
1	Overview of instruments and controls	
2	Keys and Doors	
3	Occupant restraint systems	
4	Steering wheel and Mirrors	
5	Lights, Wipers and Defogger	
6	Gauges, Meters and Service reminder indicators	
7	Ignition switch, Transmission and Parking brake	
8	Audio system	
9	Air conditioning system	
10	Other equipment	
2	INFORMATION BEFORE DRIVING YOUR TOYOTA	
3	STARTING AND DRIVING	
4	IN CASE OF AN EMERGENCY	
5	RUST PREVENTION AND APPEARANCE CARE	
6	VEHICLE MAINTENANCE AND CARE	
7	DO-IT-YOURSELF MAINTENANCE	
1	Introduction	
2	Engine and Chassis	
3	Electrical components	
8	SPECIFICATIONS	
9	REPORTING SAFETY DEFECTS FOR U.S. OWNERS	
10	INDEX	

Fig. 3-1

3. Owner's Manual Sticker Placement

- (a) Retrieve the Owner's Manual from the glove compartment.
- (b) Open to Table of Contents. Go to Section 4: IN CASE OF AN EMERGENCY. (Fig 3-1)
- (c) In Section 4, go to: "If you have a flat tire". (Fig. 3-2)

SECTION 4	
IN CASE OF AN EMERGENCY	
If your vehicle will not start	274
If your engine stalls while driving	277
If you cannot increase engine speed	277
If your vehicle overheats	278
If you have a flat tire	279
If your vehicle becomes stuck	290
If your vehicle needs to be towed	291
If you cannot shift automatic transmission selector lever	296
If you lose your keys	296

Fig. 3-2

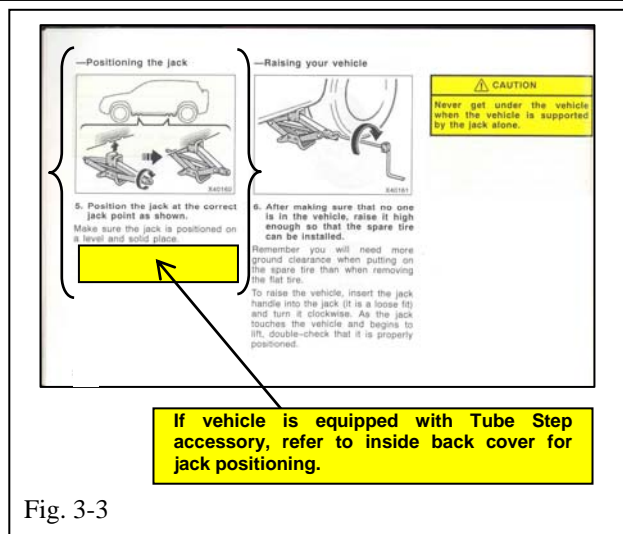

Within the “If you have a flat tire” section, you will find the “Positioning the jack”. section. (Fig. 3-3)

(d) In this section, locate this image and place the 1/2” x 2-1/2” yellow sticker on the page as shown. (Fig. 3-3)

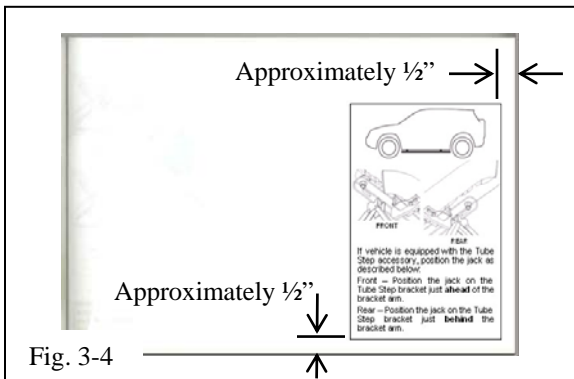

(e) Go to the inside back cover of the owner’s manual.
(f) Place the 2” x 3” white sticker on the inside cover as shown. (Fig. 3-4)

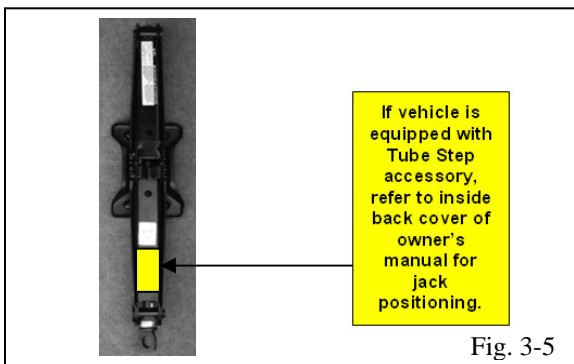

4. Jack Sticker Placement

- (a) Remove the jack. See “Required tools and spare tire” for jack location.
- (b) Make sure jack is free from dirt and grease.
- (c) Place the 1” x 1-1/2” yellow sticker on the jack as shown. (Fig. 3-5)
- (d) Replace the jack.

5. Replace the Owners Manual

- (a) Return owners manual to glove compartment.

Checklist - these points **MUST** be checked to ensure a quality installation.

Check:

Look For:

Accessory Function Checks

- Inspect bracket rail
- Inspect bolts
- Bolt tightness

(2) Bracket rails securely attached to underside rocker.

(2) Tube steps securely attached to brackets.